

Version 3

**PULSAR**

NTA 052

**TECHNICAL INSTRUCTIONS**

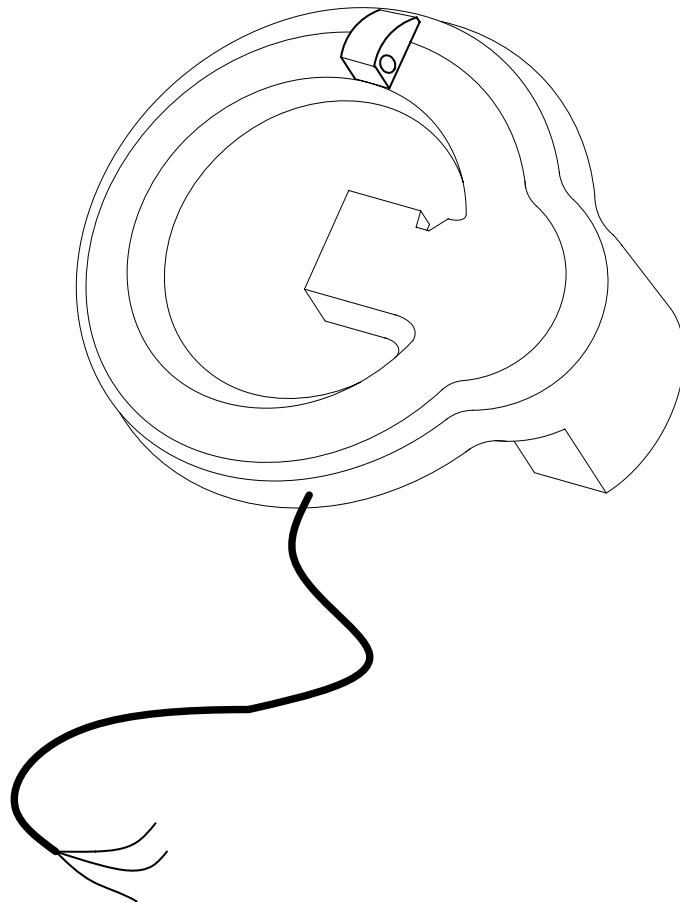

**FTA A Commissioning**

1 - Summary description	p. 1
2 - Configuration	p. 1
3 - Fitting precautions	p. 2
3.1 - Identification	p. 2
3.2 - Checking the installation	p. 2
4 - Installation on meters	p. 3
5 - Connection	p. 5
6 - Three-wire <b>Pulsar</b>	p. 6
6.1 - Operating principle	p. 6
6.2 - Connection	p. 6
7 - Four-wire <b>Pulsar</b>	p. 7
7.1 - Operating principle	p. 7
7.2 - Connection	p. 8
7.3 - Intrinsic safety	p.8

**FTA D Description**

1 - General	p. 1
2 - Operating principle	p. 1
2.1 - Description	p. 1
3 - Specifications	p. 2
3.1 - Electrical specifications	p. 2
3.2 - Mechanical specifications	p. 3
3.3 - Pulse output specifications	p. 3
3.4 - Fraud output specifications	p. 3
3.5 - Direction output specifications	p. 3
3.6 - NPN output specifications	p. 3
3.7 - Dimensions	p. 4

**FTA F Fault finding**

1 - Incidents	p.1
---------------	-----

sappel	<b>PULSAR</b>	FTA	A	0	5	2	<sup>1</sup> / <sub>8</sub>
07/00 EDITION	Commissioning						

### 1 - Summary description :

**Pulsar** is a pulse emitter with a three-metre long cable. It is powered by a cell with a life of about 12 years.

**Pulsar** is available in three-wire version (code no. 909066)

**Pulsar** is available in four-wire version (code no. 909056)

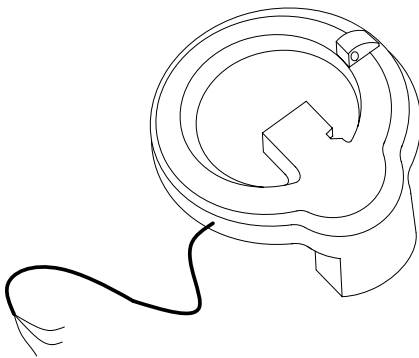

Fig.1

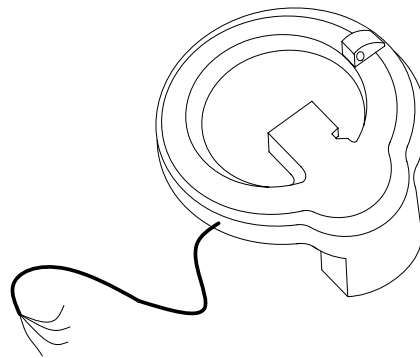

Fig.2

The standard three-wire version offers the following functions:

- pulse counting
- magnetic tamper detection
- cable cut detection
- flow direction detection

The four-wire version offers the following functions:

- pulse counting
- magnetic fraud detection
- cable cut detection
- flow direction detection
- positive and negative counting

**Pulsar** emitters are supplied in boxes of 10 units. The visible hinge of **Pulsar** units offers the facility to fit them with covers.

### 2 - Configuration :

**Pulsar** is simply clipped onto all meters of the modular Sappel range, fitted with a blue ring. It can be connected to any index transfer or remote reading system, providing the polarity is correct (see FTA A § 6.2 and § 7.2).

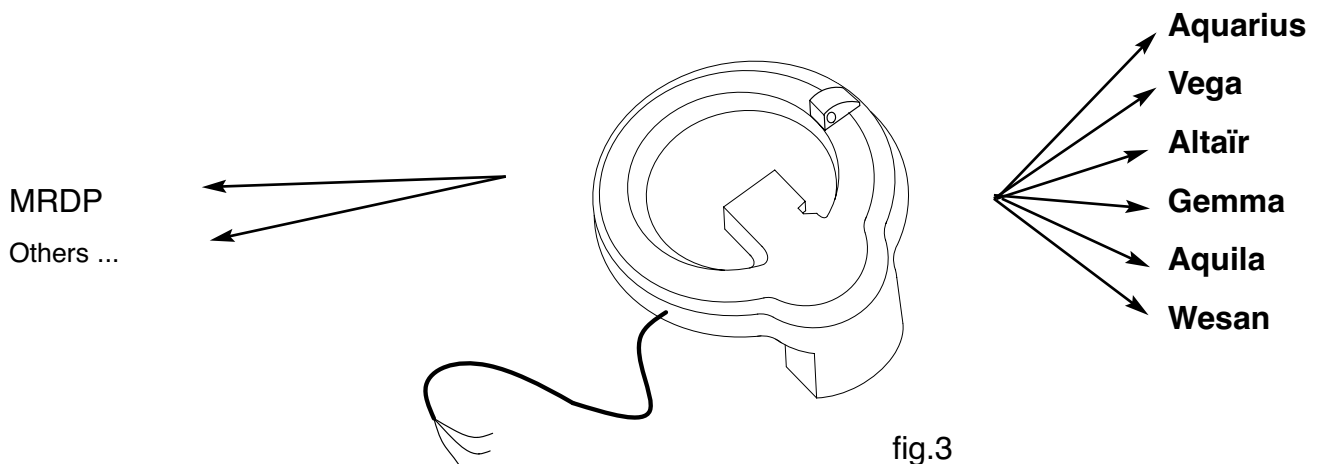

sappel	<b>PULSAR</b>	FTA	A	0	5	2	<sup>2</sup> / <sub>8</sub>
07/00 EDITION	Commissioning						

Compatibility :

- **Aquarius** : from n° 91261507 on
- **Vega** : from n° 90014801 on (Vega 110) and from n° 90009501 on (Vega 170)
- **Altair, Gemma, Aquila and Wesan** : all meters.

**3 - Fitting precautions :**

**3.1 - Identification :**

Make sure that the **Pulsar** unit is compatible with the meter on which it is to be fitted (blue **Sappel** ring).

No non-return valve is needed in as much as **Pulsar** can handle back flow (see FTA A page 6/8 § 6.1 and page 7/8 § 7.1).

If the meter has a cover, remove it by pushing out the hinge pin as shown in figure 4.

Keep aside the pin and cover for use after fitting the Pulsar unit.

Carefully clean the top of the register to remove any trace of dirt.

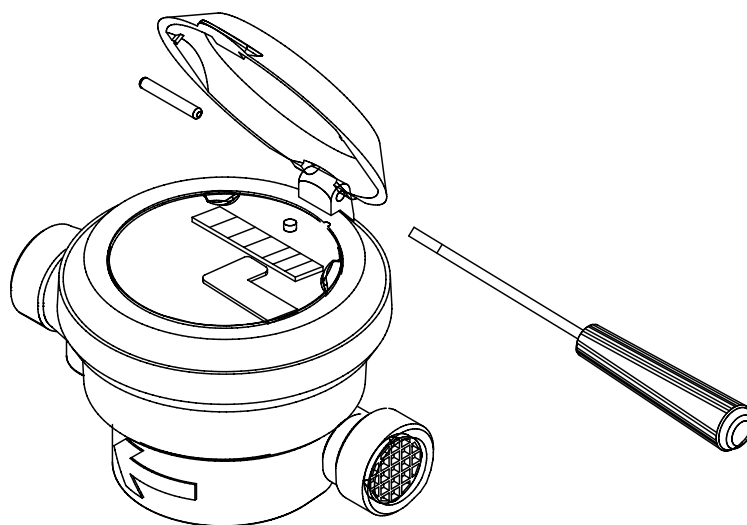

Fig 4

**3.2 - Checking the installation :**

Make sure that the electrical installation complies with the specifications of **Pulsar** as stated on the identification plate (figure 5).

**Note :**

**Pulsar is fitted with a non-replaceable lithium cell with a life of about 12 years. Take care to respect the polarity while connecting PULSAR.**

sappel	<b>PULSAR</b>	FTA	A	0	5	2	3	8	
<b>07/00 EDITION</b>	Commissioning								

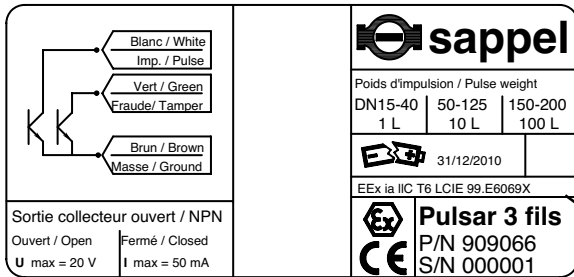

**sappel**

Poids d'impulsion / Pulse weight  
 DN15-40 | 50-125 | 150-200  
 1 L | 10 L | 100 L

31/12/2010

EEx ia IIC T6 LCIE 99.E6069X

**Pulsar 3 fils**  
 P/N 909066  
 S/N 000001

The identification tag of Pulsar is glued on its cable.

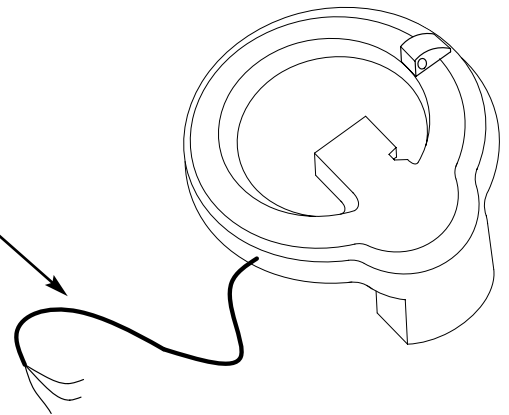
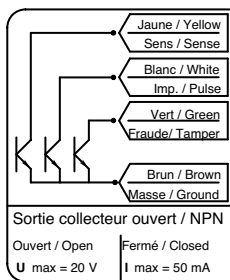

Fig.5



**sappel**

Poids d'impulsion / Pulse weight  
 DN15-40 | 50-125 | 150-200  
 1 L | 10 L | 100 L

31/12/2010

EEx ia IIC T6 LCIE 99.E6069X

**Pulsar 4 fils**  
 P/N 909056  
 S/N 000001

- **Pulsar** must be fitted in a location where the temperature does not exceed 70°C. However, it is designed to withstand 100% hygrometry. It may be immersed under 1 metre of water (IP 685).

- **Pulsar** offers **intrinsic safety under EExia IIC T6**, providing the values  
**U max = 20 V** and  
**I max = 50 mA**  
 are not exceeded and that the device has never been used with values beyond those limits.

- **Pulsar** may be used outside explosive zones with maximum values  
**U max = 60 V** and  
**I max = 200 mA.**

Under such conditions, Pulsar will be operational but will irretrievably lose its intrinsic safety features.

The fitter shall be responsible for any installation that does not comply with the recommendations above. Sappel shall have no liability in respect of such installations.

**4 - Installation on meters of the modular Sappel range :**

Remove the meter cover (if any) by pushing out the pin.

Locate the small point on the metering apparatus.

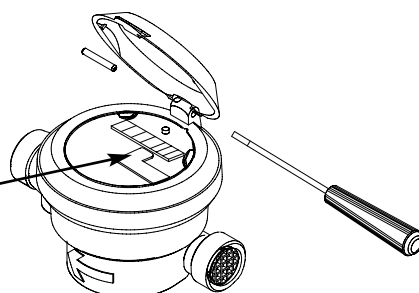

Fig. 6

sappel	<b>PULSAR</b>	FTA	A	0	5	2	<sup>4</sup> / <sub>8</sub>
07/00 EDITION	Commissioning						

Position the **Pulsar** emitter so that the point on the register is aligned with the notch on the ring under the Pulsar hinge.

Press the **Pulsar** ring onto the register till it clicks in place.

Put the meter cover back onto the meter.

The installation of Pulsar is completed.

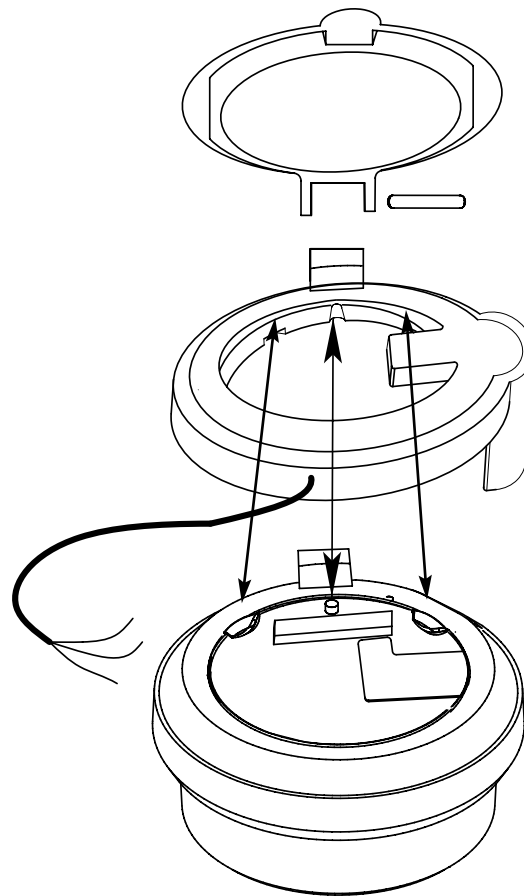

" CLIC"

Fig. 7

**Note :**

If **Pulsar** is to be fitted and removed often (e.g. leak detection on network etc.), you could file one of the fixing tabs of the Izar module to make it easier to fit and take off.

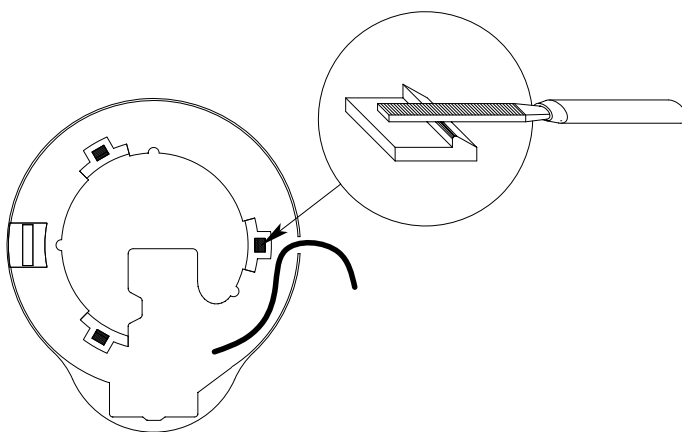

**Important :**

Filing a tab will make fitting and removing easier to perform, but it will reduce the effectiveness of the system by which **Pulsar** is fitted to the meter.

sappel	<b>PULSAR</b>	FTA	A	0	5	2	5	8	
07/00 EDITION	Commissioning								

## 5 - Connection :

The **Pulsar** cable contains 3 or 4 insulated conductors in a protective sheath. Connect the wires carefully using the connectors supplied with **Pulsar**.

The connectors include a plastic housing containing a self-stripping blade.

The housing is closed by a sealing cap (see fig. 8).

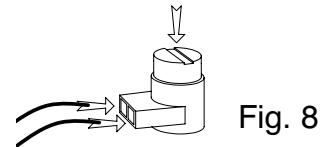

Fig. 8

Place the two wires you want to connect in the connector. Press them with special pliers **without stripping them**. The self-stripping blade will cut the insulation down to the conducting core, thereby ensuring connection. The gel bag will be broken, and it will cover the splice and the connection in the capsule (see fig. 9).

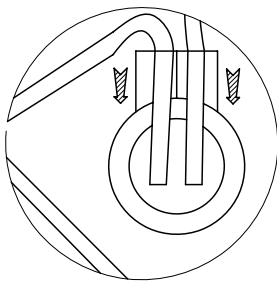

Fig.9

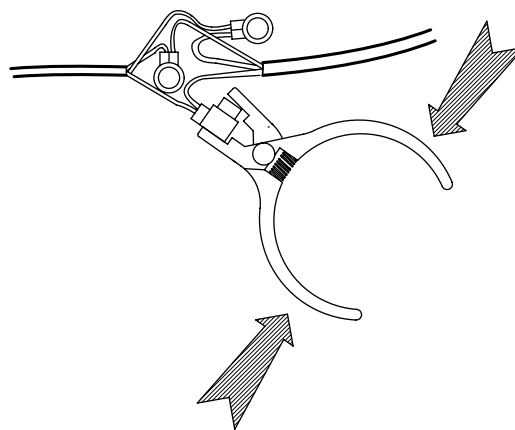

Fig. 10

Stop tightening when the colour capsule has fully entered into the transparent part. Ideal fastening is obtained using E9BM or E9Y pliers from 3M.

**The connectors are sealed from ambient humidity but are not waterproof.**

### NB :

For more difficult cases (when the connectors are kept immersed), an immersion sealing kit is available (code no. 870 090). Please contact your **Sappel** agent.

sappel	<b>PULSAR</b>	FTA	A	0	5	2	6	8	
07/00 EDITION	Commissioning								

## 6 - Three-wire Pulsar :

### 6.1 - Operating principle :

Three-wire **Pulsar** pulse emitters take account of the direction of the flow, i.e. they do away with the need for a non-return valve.

#### Principle :

If the water flows back, a three-wire **Pulsar** unit will not send a pulse. When the flow resumes its normal direction, Pulsar will only start transmitting pulses again when the forward flow has made up for the previous back flow (up to a maximum of 250 pulses).

#### Example for a meter with a DN of 15 mm, where a pulse is sent with each litre:

- |                          |                      |
|--------------------------|----------------------|
| - flow of 100 litres     | = 100 pulses         |
| - back flow of 50 litres | = no pulse           |
| - flow of 100 litres     | = 50 pulses (100-50) |
| 100-50+100=150 litres    | 100+50=150 pulses    |

Pulsar can allow for back flow of up to 250 pulses, i.e. :

- 250 litres for DN 15-40 meters
- 2500 litres for DN 50-125 meters
- 25 000 litre for DN 150-200 meters

### 6.2 - Connection :

**Pulsar** emitters are connected to index repeaters or other pulse counting systems via the brown wire (earth) and the white wire (pulses).

The tamper detection facility is provided by connecting the green wire (see figure 11) to detect any attempt to tamper with the meter magnetically or by cutting the transmitter cable.

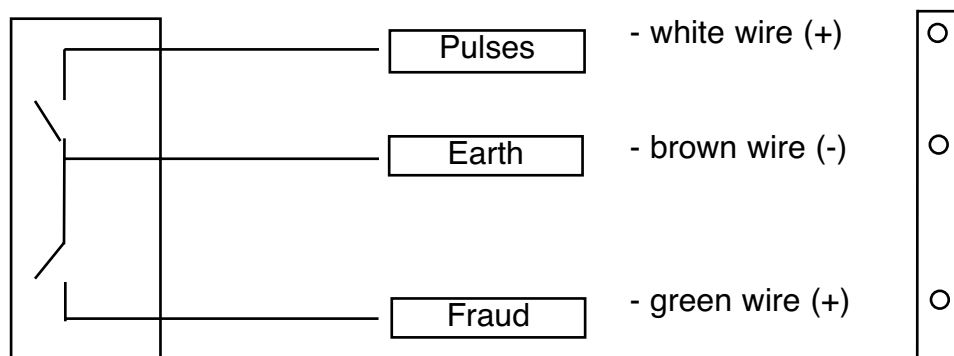

Fig. 11



Correct wire polarity is of crucial importance. Otherwise, you could damage the **Pulsar** unit (if the power supply is greater than 60V/200 mA) or it may not be able to generate useful signals.



**Pulsar** offers intrinsic safety providing the values  $U_{max} = 20\text{ V}$  and  $I_{max} = 50\text{ mA}$  are not exceeded and that the device has never been used with values beyond those limits.

sappel	<b>PULSAR</b>	FTA	A	0	5	2	7	8	
07/00 EDITION	Commissioning								



**Pulsar** may be used outside explosive zones with maximum values

U max = **60 V** and I max = **200 mA**.

Under such conditions, **Pulsar** will be operational but will irretrievably lose its intrinsic safety features.

The fitter shall be responsible for any installation that does not comply with the recommendations above. **Sappel** shall have no liability in respect of such installations.

## 7 - Four wire Pulsar :

### 7.1 - Operating principle :

Four-wire **Pulsar** units supply signals which are used to determine the volume of water moving in either flow direction, **using appropriate processing circuitry**.

#### Principle :

**Pulsar** delivers pulses to indicate flow in either direction (white wire), along with a direction signal (yellow wire), where each pulse is allocated a direction.

#### Example of chronogram : (see fig. 12)

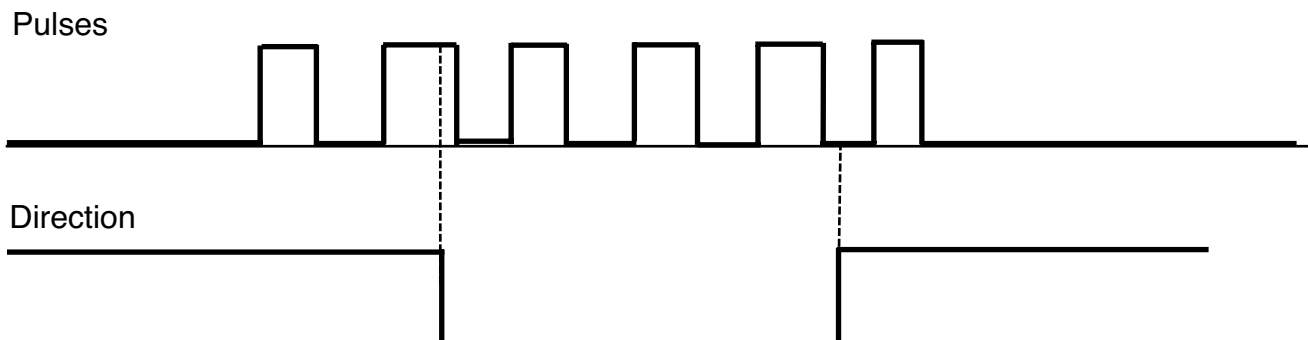

Fig. 12

In the case above, **Pulsar** delivers six pulses and the additional direction information, which indicates that the first two pulses are positive, the three following pulses are negative and the last one is positive.

- Two litre forward flow : 2 pulses, direction "+"
- Three litre back flow : 3 pulses, direction "-"
- One litre forward flow : 1 pulse, direction "+"

NB : Four-wire **Pulsar** units can therefore only be used with an electronic system which can handle the two signals, namely pulse and direction.

sappel	<b>PULSAR</b>	FTA	A	0	5	2	8	8
07/00 EDITION	Commissioning							

## 7.2 - Connection :

Four-wire **Pulsar** units are connected to index repeaters or other pulse counting systems via the brown wire (earth) and the white wire (pulse).

The fraud detection facility is provided by connecting the green wire to detect any attempt to tamper with the meter magnetically or by cutting the transmitter cable.

The direction signal is provided by the direction output, yellow wire.

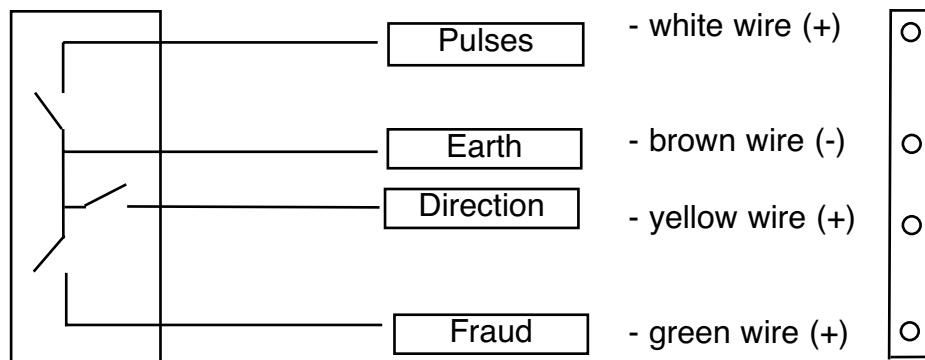

Fig. 13



**Correct wire polarity is of crucial importance. Otherwise, you could damage the Pulsar® unit or it may not be able to generate useful signals.**

**NB: If the direction signal (yellow wire) is not used, all the pulses will be considered to be positive.**

**If in doubt, contact your Sappel agent to validate the compatibility of the equipment used.**



**Pulsar** offers intrinsic safety providing the values  $U_{max} = 20\text{ V}$  and  $I_{max} = 50\text{ mA}$  are not exceeded and that the device has never been used with values beyond those limits.



**Pulsar** may be used outside explosive zones with maximum values  $U_{max} = 60\text{ V}$  and  $I_{max} = 200\text{ mA}$ .

Under such conditions, **Pulsar** will be operational but will irretrievably lose its intrinsic safety features.

The fitter shall be responsible for any installation that does not comply with the recommendations above. **Sappel** shall have no liability in respect of such installations.

## 8 - Intrinsic safety

**Pulsar** offers intrinsic safety under : **EEx ia ii C T6**

The intrinsic safety number is : **LCIE 99.E6069X**

sappel	<b>PULSAR</b>	FTA	D	0	5	2	1	4	
07/00 EDITION	Description								

## 1 - General :

**Pulsar** is an electric pulse emitter of the open collector NPN type. It is powered by a cell with a life of about 12 years.

**Pulsar** comprises a ring made of grey PC ABS (unbreakable synthetic material) and a one-metre electrical cable with 3 or 4 wires.

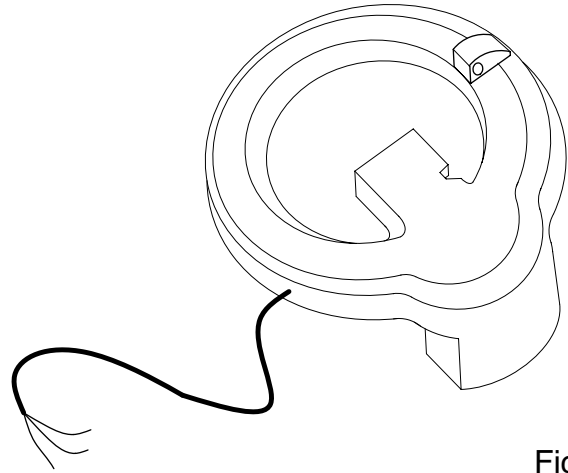

Fig 14

**Pulsar** has an electronic circuit containing flexible blade switches which let the current through each time a litre (or ten litres) goes (go) through the meter.

**NB :** DN 15-40 **Sappel** meters transmit a pulse with every litre  
 DN 50-125 **Sappel** meters transmit a pulse with every 10 litres,  
 DN 150-200 **Sappel** meters transmit a pulse with every 100 litres,  
 each time the metering disc completes a revolution (see details in figure 16).

## 2 - Operating principle :

### 2.1 - Description :

A ring with flexible blade switches and a “Dirflux” ASIC (Application-Specific IC) receives the signals, processes them and sends them on in the form of open collector signals (polarised).

An additional flexible blade switch sends a signal to report any tampering with an outside magnet.

sappel	<b>PULSAR</b>	FTA	D	0	5	2	<sup>2</sup> / <sub>4</sub>
<b>07/00 EDITION</b>	Description						

The switches in the Pulsar unit are moved by a magnet placed under the metering disc of Sappel modular totalling registers.

Each disc revolution is equivalent to one signal.

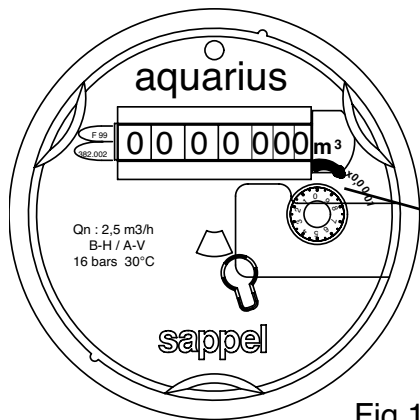

Fig.15

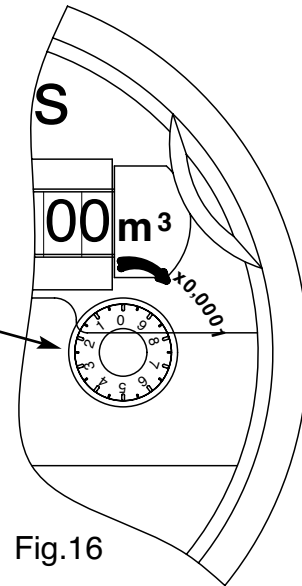

Fig.16

### 3 - Specifications :

#### 3.1 - Electrical specifications :

Electrical signals are transmitted via a one-metre long cable with 3 or 4 insulated conductors.

The cell has an approximate life of 12 years. It is not replaceable.

#### Three-wire Pulsar

- Flexible non-shielded cable with 3 wires, section 0.34 mm<sup>2</sup>.
- Brown: earth
- White: pulse
- Green: fraud

#### Four-wire Pulsar-

Flexible non-shielded cable with 4 wires, section 0.25 mm<sup>2</sup>.

- Brown: earth
- White: pulse
- Green: fraud
- Yellow: direction flow

sappel	<b>PULSAR</b>	FTA	D	0	5	2	3	4
07/00 EDITION	Description							

### 3.2 - Mechanical specifications :

**Pulsar** is compatible with all the meters of the modular **Sappel** range, which can be recognised by their blue ring :

- **Aquarius**: from n° 91261507 on
- **Vega**: from n° 90014801 on (Vega 110) and from n° 90009501 on (Vega 170)
- **Altair, Gemma, Aquila** and **Wesan**: all meters.

Storage temperature	-30°C to +80°C
Operating temperature	-15°C to +55°C
Protection rating	IP 685
Electromagnetic compatibility	CE

### 3.3 - Pulse output specifications :

- transistor output of the open collector NPN type
- closed when there is a pulse
- for a constant flow, the cyclical ratio is 50%
- bounce-free status change (no noise in signal)

### 3.4 - Fraud output specifications :

- transistor output of the open collector NPN type
- open if fraud

### 3.5 - Direction output specifications in four-wire Pulsar units :

- transistor output of the open collector type
- closed when the flow is reversed
- bounce-free status change

### 3.6 - NPN output specifications :

- Maximum frequency 25 Hz

- Open state: Voltage < 20V - Closed state: Current 50 mA	In this case, <b>Pulsar</b> offers intrinsic safety and may be used in explosive zones.
--------------------------------------------------------------	-----------------------------------------------------------------------------------------

- Open state: Voltage < 60V - Closed state: Current 200 mA	In this case, <b>Pulsar</b> is operational. However, it ceases to offer intrinsic safety and may not be used in explosive zones.
---------------------------------------------------------------	----------------------------------------------------------------------------------------------------------------------------------

sappel	<b>PULSAR</b>	FTA	D	0	5	2	4	4	
07/00 EDITION	Description								

**3.7 - Dimensions :**

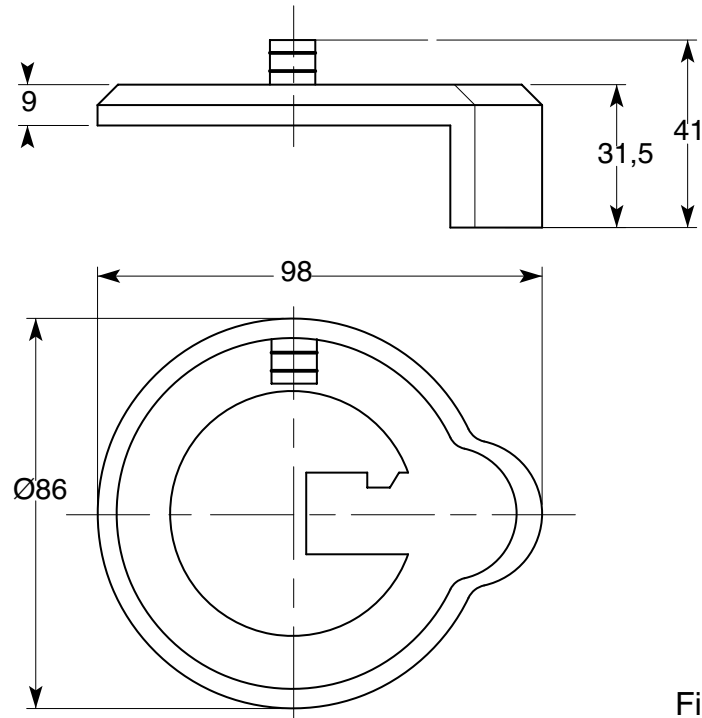

Fig.17

sappel	<b>PULSAR</b>	FTA	F	0	5	2	1	1
07/00 EDITION	Fault finding							

### 1 - Incidents :

If no pulse is transmitted:

- Check if the polarity is correct (see FTA A § 6.2 and § 7.2)
- Check the quality of the connection at the connectors
- Check the condition of the cable

Notes :

- **Pulsar** does not require any outside power supply. It is powered by a non-replaceable cell with a life of about 12 years.
- Four-wire **Pulsar** units can only be used with circuitry which allows for the use of such devices.



**Correct wire polarity is of crucial importance. Otherwise, you could damage the Pulsar unit or it may not be able to generate useful signals.**