

Version 1.3

up to date 02/01

izar[®]
MRCP

NTA 032

TECHNICAL INSTRUCTIONS

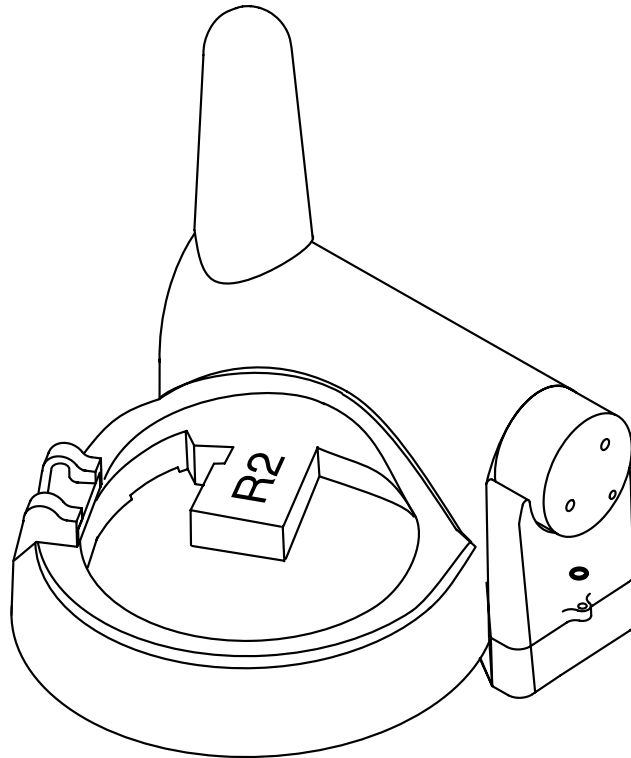

FTA A Commissioning

1 - Summary description	p.1
2 - Compatibility with Sappel meters	p.1
3 - Installing the battery	p.2
4 - Fitting the Izar _{MRCP} "R2" on the meters	p.3
5 - Programming the Izar _{MRCP} "R2" radio unit	p.3
5.1 - Reprogramming the radio unit	p.4
5.2 - Outside the explosive area	p.4
5.3 - Within the explosive area	p.4
6 - Sealing the battery compartment	p.5

FTA C Maintenance

1 - Battery replacement	p.1
2 - Maintenance	p.2

FTA D Description

1 - General presentation	p.1
2 - Operating principle	p.1
2-1 Operation	p.1
2-2 Back flow detection	p.1
2-3 Communication	p.2
2-4 Environment	p.2
3 - Technical characteristics	p.2
4 - Performance	p.3
5 - Dimensions	p.3

FTA F Fault finding

1 - Fault analysis	p.1
--------------------	-----

sappel	izar MRCP	FTA	A	0	3	2	1 5
02/01 EDITION	Commissioning						A&R

1 - Summary description :

Izar_{MRCP} "R2" is a two-way transceiver designed for Sappel meters. The R2 version is different from the previous version in that it is powered by a new cell with a life of about 10 years. Also, it is different from the Dirflux pulse sensing system, which take account of back flow.

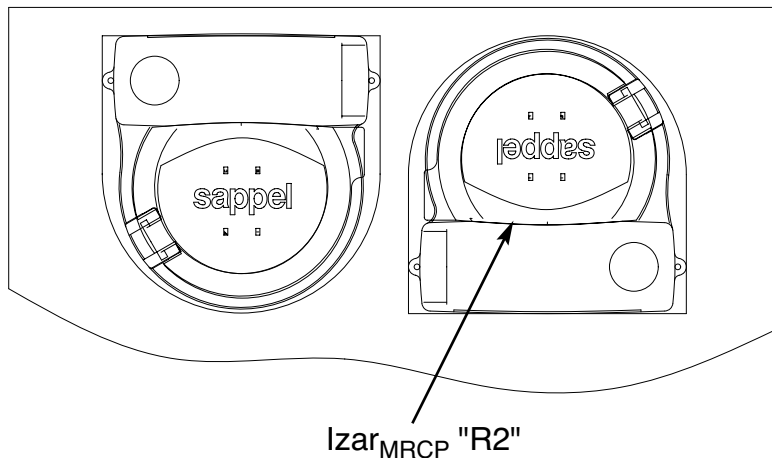

Packaging :

- 10 Izar_{MRCP} R2 units
- 10 batteries
- 10 sealing plastic wires
- 10 sealing labels
- 10 caps
- 1 spanner

2 - Compatibility with Sappel meters :

Izar_{MRCP} is compatible with all the meters of the modular Sappel range.

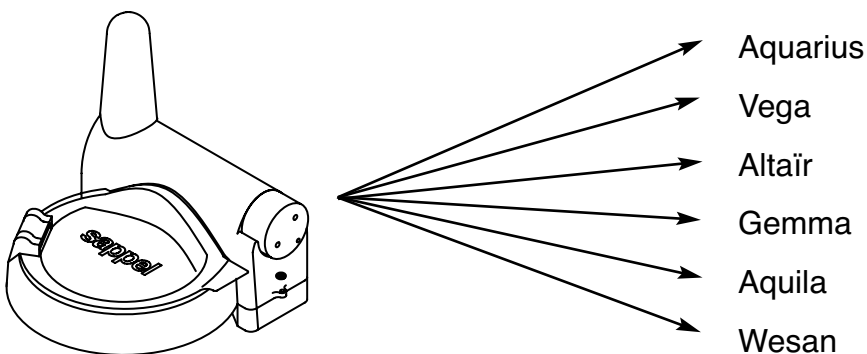

sappel	izar MRCP	FTA	A	0	3	2	² / ₅
02/01 EDITION	Commissioning						A&R

3 - Installing the battery :

NB : Before fitting Izar_{MRCP} on the meter and programming it, you must first insert the battery in the battery compartment.

Never install the batteries in several Izar_{MRCP} units at the same time.

Never install a battery in a radio unit before programming the previous radio unit.

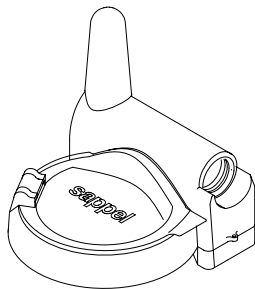

A. Battery compartment

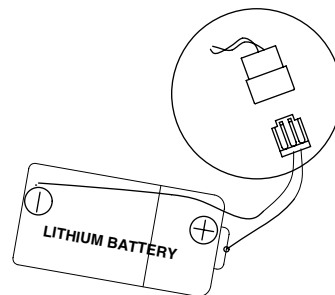

B. Connect the battery

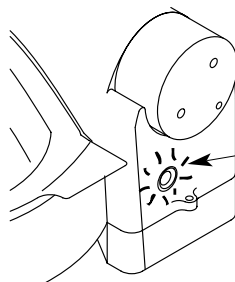

The diode lights up for 2 seconds : the card is being charged. The diode keeps flashing until the module is programmed.

C. Close the battery compartment

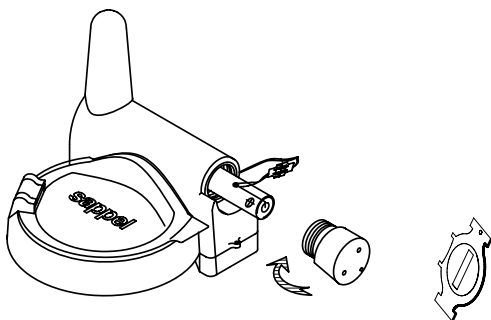

The connection is to be fitted into the cap. Screw in the cap by hand and complete tightening using the spanner. Do not over-tighten (a quarter turn).

NB: Each Izar_{MRCP} radio unit is to be programmed before the battery is fitted into the following radio unit to make sure that Izar_{MRCP} radio units are correctly initialized: should this procedure not be followed, Sappel cannot be held responsible for the radio unit dysfunction.

sappel	izar [®] MRCP	FTA	A	0	3	2	3	5
02/01 EDITION	Commissioning							A&R

4 - Fitting the IzarMRCP radio unit on the meter :

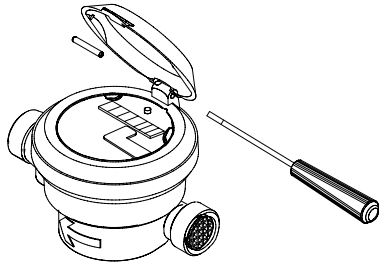

- remove the meter cover using a pin drift
- clean the register dial

- position the module over the register

- clip the module by pressing down with both hands

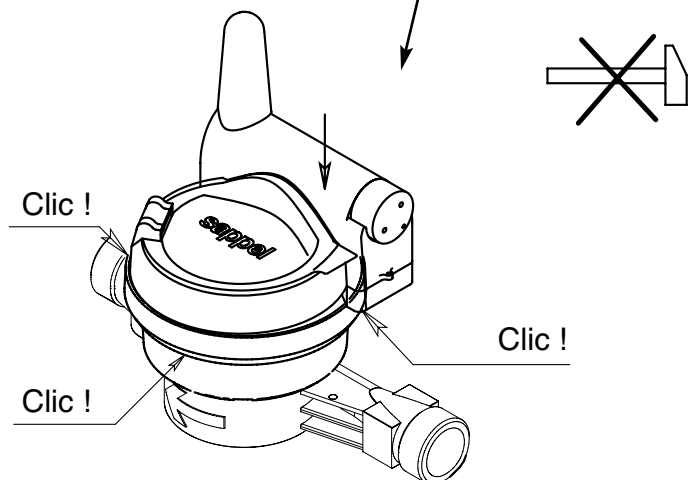
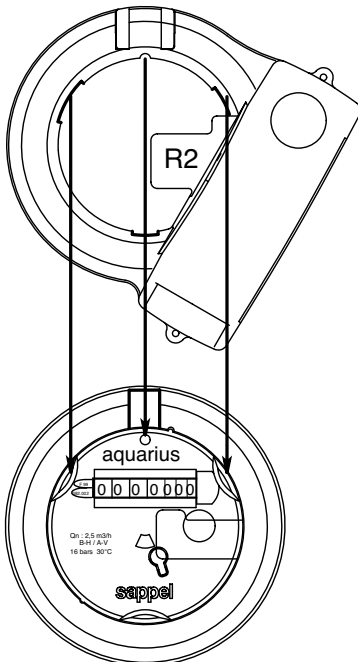

5 - Programming the IzarMRCP :

For more information about programming, refer to the service instructions of handheld computers (Psion or Husky, as applicable). While validating the program with the Enter key, take care to hold **the handheld computer at least 1.5 metres away from IzarMRCP.**

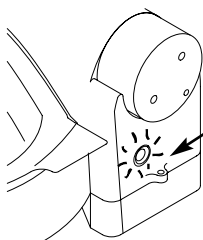

During the set-up procedure (meter number, release file and index), the LED will flash to indicate that data are being received.

sappel	izar MRCP	FTA	A	0	3	2	4	5	
02/01 EDITION	Commissioning							A&R	

NB :

For version file programming, select **R2** if that is stated on the product. If nothing is stated, select R1 (previous generation).

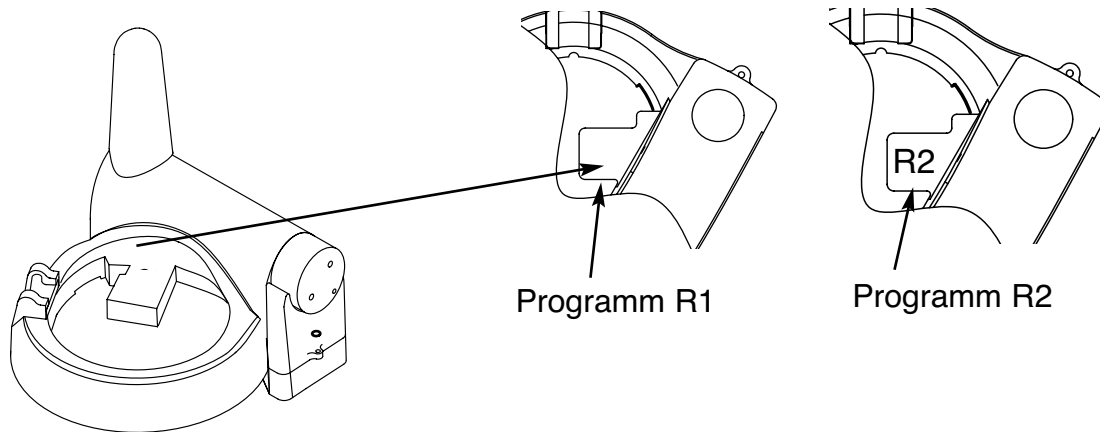

5.1 Reprogramming the radio unit :

If you make a mistake while entering the meter number, repeat the setting procedure.

5.1.1 – Outside the explosive area

Proceed as follows : open the cap, disconnect the cell and short the radio unit output connector. Connect the cell once again and make sure that the LED is steady for 2 seconds and then flashes every second.

Set the radio unit with the handheld computer.



This operation must be performed outside the explosive area.

5.1.2 – Within the explosive area

Do not short the connector, it may lead to an explosion.

It is imperative to follow the procedure below:

- Disconnect the cell of the radio unit
- Query the radio unit three times with the handheld computer. At the third attempt, the radio will cease to respond as it will be discharged. If that is not so, query the radio unit once again.
- Connect the cell and check that the LED located under the cell housing is steady for 2 seconds and then flashes every second, to show that the radio is ready for setting.
- Set the radio module with the handheld computer

sappel	izar MRCP	FTA	A	0	3	2	5	5
02/01 EDITION	Commissioning							A&R

6 - Sealing the battery compartment :

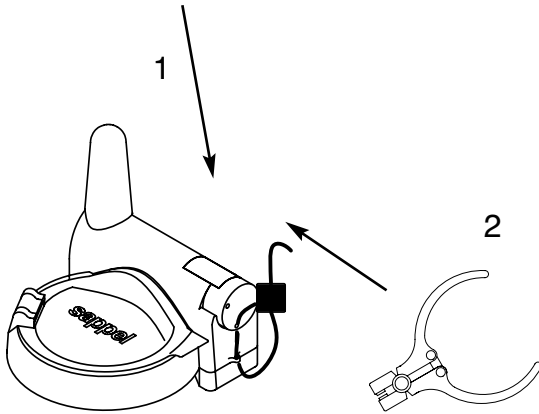

Before the battery compartment is sealed, take a test radio reading.

It can be sealed using either a specific label (1) or a plastic sealing wire (2).

NB: as with all devices using radio frequency, the reading distance may be affected by the radio-electric environment and the configuration of the land.

NB: the product shall be installed and used in strict compliance with these instructions. Sappel shall have no liability in respect of operations or installations that do not comply with good workmanship practices or these instructions.

sappel	izar MRCP	FTA	C	0	3	2	1 / 2
02/01 EDITION	Maintenance						A&R

1- Replacing the battery :

The battery of Izar_{MRCP} "R2" has a life of about 10 years (**for guidance only**).

That can vary depending on the reading frequency and the climatic conditions of its environment (temperature).

Every time the Izar_{MRCP} module is interrogated the battery state "battery ok", or "battery replacement" is displayed on the handheld computer. If the battery is spent, the handheld computer indicates "battery replacement".

Important: while changing the battery, make sure to use the special cell for R2 versions (code no. 520195, marked P2).

How to replace the battery :

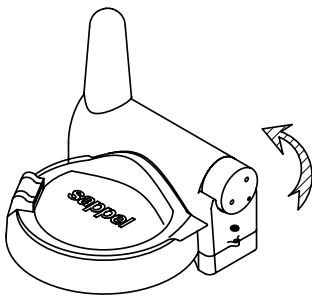

A. Unscrew the cap

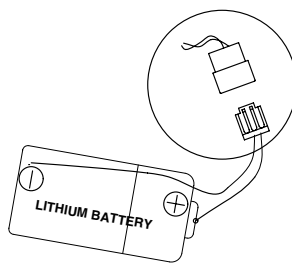

B. Disconnect the spent battery and connect the new one **within 20 seconds**

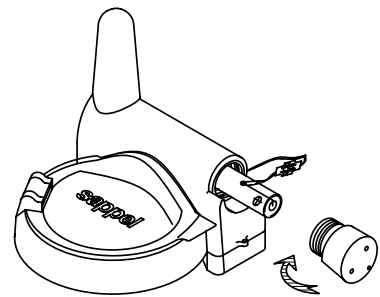

C. Close the compartment

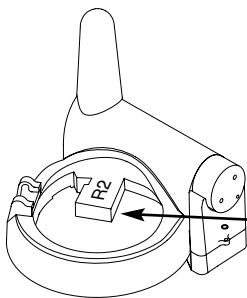

IMPORTANT :

D. Activating the battery change function on the handheld computer is indispensable (see relevant instructions).

Also, the correct radio version file in use must be confirmed, i.e. R1 or R2 (see FTA page 3/4, §5).

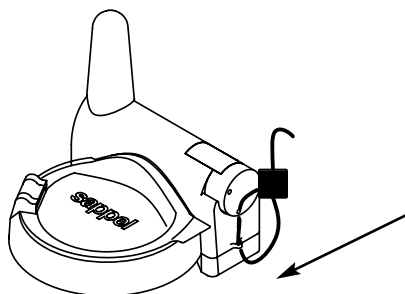

E. Make sure that the Izar_{MRCP} radio unit is operating by doing a radio reading test and check if the cell is fully charged (100%).

F. Seal the cell compartment.

Note : there is no need to reprogram the Izar_{MRCP} unit completely if the cell change (disconnection/connection) is completed **within 20 seconds**. Otherwise, you will have to reprogram the Izar MRCP/MRDP radio unit with the meter number via the handheld terminal.

sappel	izar MRCP	FTA	C	0	3	2	² / ₂
02/01 EDITION	Maintenance						A&R

2 - Maintenance :

izar_{MRCP} does not require specific maintenance other than changing the cell.

Do not clean the unit with solvents or abrasive agents which could damage the plastic cover of izar_{MRCP}. If required, clean with a moist cloth or sponge.

Storage :

The product can be stored in a dry place at a temperature of -30°C to +55°C if the battery is disconnected.

sappel	izar MRCP	FTA	D	0	3	2	1	3
02/01 EDITION	Description							A&R

1 - General description :

The Izar_{MRCP} radio unit is a bi-directional emitter/receiver and operates using an international and interprofessional communication standard; the "RMS standard".

Izar_{MRCP} is compatible with any meter from the Sappel modular range (Aquarius, Vega, Altair, Gemma, Aquila).

The Izar_{MRCP} radio unit is composed of below elements :

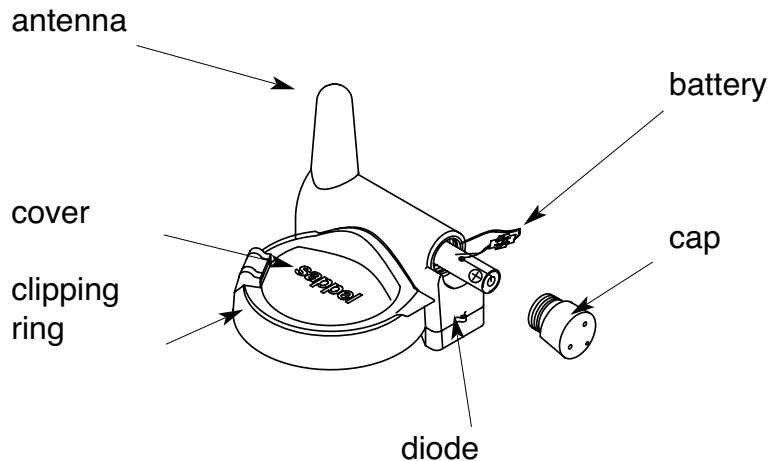

2 - Operating principle :

2.1 - Operation :

The Izar_{MRCP} radio unit uses circuitry with low power requirements built around a special micro-processor and the HF (High Frequency) part. It comprises an electronic circuit which receives data transmitted by an ILS (Reed) type pulse emitter and stores it in a memory bank. Upon reception of the identification signal the Izar_{MRCP} "R2" radio unit emits the data.

The built-in software of the handheld computer then displays the real meter index.

2.2 - Back flow detection :

Izar_{MRCP} "R2" has a pulse sensor with flexible blade switches and an ASIC (Application-Specific Integrated Circuit) called "Dirflux", which enables it to take account of back flow.

Meters fitted with Izar_{MRCP} "R2" do not need to have non-return valves.

Principles :

If the water flows back, Izar_{MRCP} "R2" does not transmit any pulse. When it starts flowing in the usual direction, Izar_{MRCP} "R2" only starts transmitting pulses when enough water has gone through the meter to make up for the back flow (up to a maximum of 250 pulses).

Example for a DN 15 meter: (pulse with each litre)

- 100 litre flow	= 100 pulses
- 50 litre back flow	= no pulse
- 100 litre flow	= 50 pulses (100-50)
<hr/> 100-50+100=150 litre	<hr/> 100+50=150 pulses

sappel	izar MRCP	FTA	D	0	3	2 ²	3
02/01 EDITION	Description						A&R

2.3 - Communication :

Izar operates using the «standard RMS» ; the latter is composed of radio protocol, between the handheld computer and Izar_{MRCP}, and the internal protocol of the handheld computer called «PIP».

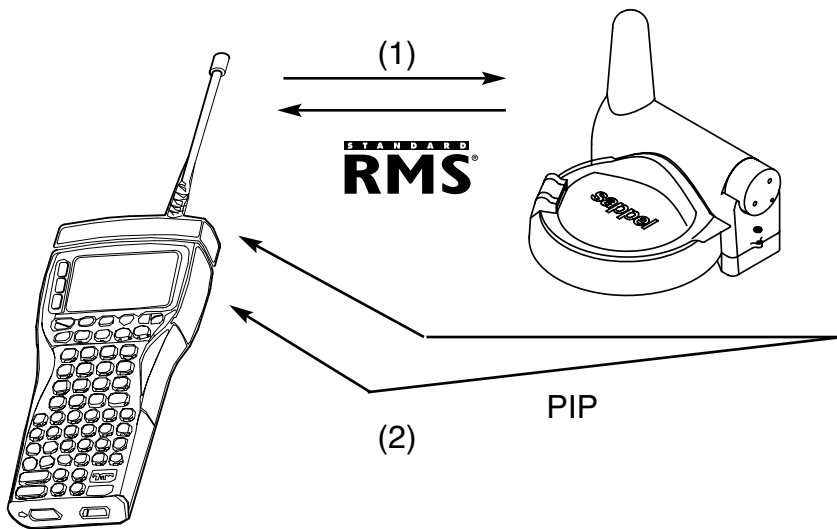

(1) The Izar_{MRCP} radio unit communicates with the handheld computer radio head through the «RMS» protocol.

(2) Communication between the handheld computer radio head and the handheld computer itself is provided by the «PIP» protocol.

These protocols together make up the «**standard RMS**».

2.4 - Environment :

The Izar_{MRCP} radio unit can be fitted onto any Sappel meter equipped with a blue ring and can resist total and long (several months) immersions. The operating temperature range extends from -15°C to +55°C.

3 - Technical characteristics :

Frequency band	433,92 Mhz
Standard	I-ETS 300 220
Approval (*)	ART N° 990265 PPL O / 990294 PPL O
Electromagnetic compatibility	CE
Battery	Lithium 3 V
Autonomy	10 years depending on reading frequency
Pulse emitter	Dry contact (reed)
Meters	Sappel modular range
Temperature range	from -15C° to +55°C
Protection level	IP685 - immersion

(*) This product has been found to be conforming by the Telecommunications Regulation Authority. An identification card from that authority is available on request (please call your Sappel agent).

sappel	izar MRCP	FTA	D	0	3	2	3	3
02/01 EDITION	Description							A&R

4 - Performance :

Example of meter site reading distances	
Location of meter fitted with izar _{MRCP} module	Maximum reading distances (in metres)
Waterbox full of water	15
Waterbox waterproof	40
Manhole in the middle of the street	50
Basement of house	60
Technical shaft in a block of flats	70
Ground floor of a house	100
Outdoors	600

5 - Dimensions :

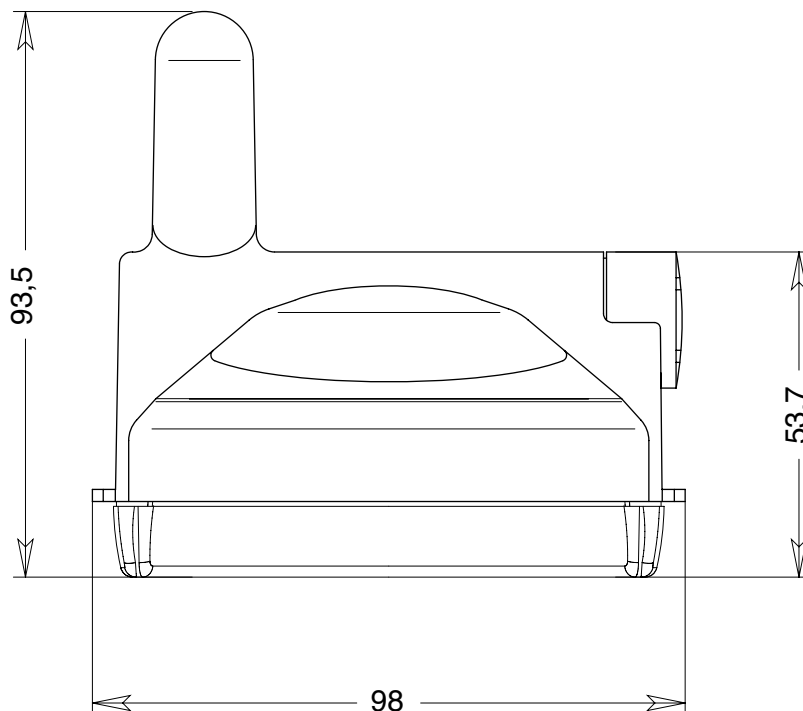

sappel	izar MRCP	FTA	F	0	3	2	1 1
02/01 EDITION	Fault finding						A&R

1 - Fault analysis :

When reading the Izar_{MRCP} the following faults might be observed :

Action	Fault	Checks
Interrogation	no index displayed	check the meter number
Interrogation	no response	check visually the radio unit
Interrogation	no index read	get closer to the meter
Interrogation	reception difficulties	check the battery charge state