

S-010 AUTOMATIC AIR RELEASE VALVE



The automatic valve float, coated with soft rubber, ensures sealing at low pressures.

The automatic valve plastic screen basket prevents contact between the float and the casting, enabling smoother operation.

Standard cast iron body - baked polyester coating.

Working pressure range: 0.2-16 bar. (3-230 psi).

Available in 1/2" (15mm), 3/4" (20mm), 1" (25mm), BSPT/NPT Threaded.

Ordering

Upon ordering, please specify: model, size, working pressure, threads standard and type of liquid.



A.R.I. Flow Control Accessories

Kfar Charuv, 12932 Israel Tel. 972-6-6761988 Fax. 972-6-6763402

<http://arivalves.com>

ECS0102000

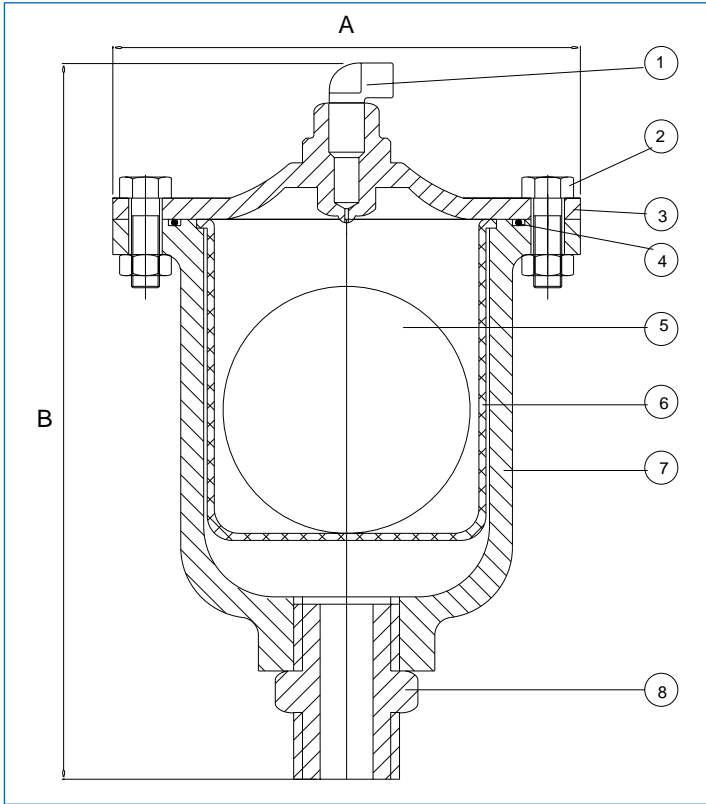

PARTS LIST AND SPECIFICATION

No.	Part	Material
1.	Drainage Elbow	Brass
2.	Bolt and Nut	Galvanized Steel Chromate Plated
3.	Cover with nozzle	Brass ASTM B-124
4.	O-Ring	BUNA-N
5.	Float	Polycarbonate, Natural Rubber Coated
6.	Screen - Basket	Polypropylene
7.	Body	Cast Iron ASTM A-48 CL.35B
8.	Male Adapter	Brass ASTM B-124

AUTOMATIC AIR DISCHARGE CHART

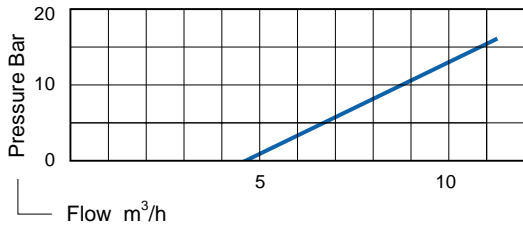

DIMENSIONS AND WEIGHT

Nominal Size			A	B	Weight Kg	Orifice Area mm ²
15mm	20mm	25mm	132.5	199	3.5	0.785
1/2"	3/4"	1"				

