

D-020 COMBINATION AIR VALVE FOR SEWAGE - "SAAR"

Guarantees complete separation of the liquid from the sealing mechanism by creating an air gap at the top of the valve.

- The air gap, guaranteed even under extreme conditions, is achieved by a conical body shape that maintains maximum distance between the liquid and the Sealing Mechanism; while obtaining minimum body length.
- Spring loaded joint between the stem and the upper float, to ensure that vibrations of the lower float will not unseal the automatic valve. Release of air will occur only after the accumulation of enough air.
- Funnel-shaped lower body ensures that the residue sewage matter will sink to the system and be carried away.
- Self cleaning mechanism.

Includes A.R.I patent: Rolling Seal Mechanism.

The valve may be flushed through a ball valve at the valve's lower part.

Reliable operation reduces water hammer incidents.

Dynamic design allows high velocity air discharge, exceeding 12 Psi differential pressure; preventing premature closing.

Lightweight, small dimensions, simple and reliable structure.

All inner metal parts made of stainless steel SAE 316.

The drainage outlet enables removal of excess fluids.

Standard metal body - baked polyester coating.

Available with a Stainless Steel SAE 316 body or rilsan and enamel coatings.

Working pressure range: 3-230 Psi.

Available in 2" - 8".

Ordering

Upon ordering, please specify: model, size, working pressure, threads/flanges standard and type of liquid.



A.R.I. Flow Control Accessories

Kfar Charuv, 12932 Israel Tel. 972-6-6761988 Fax. 972-6-6763402

<http://arivalves.com>

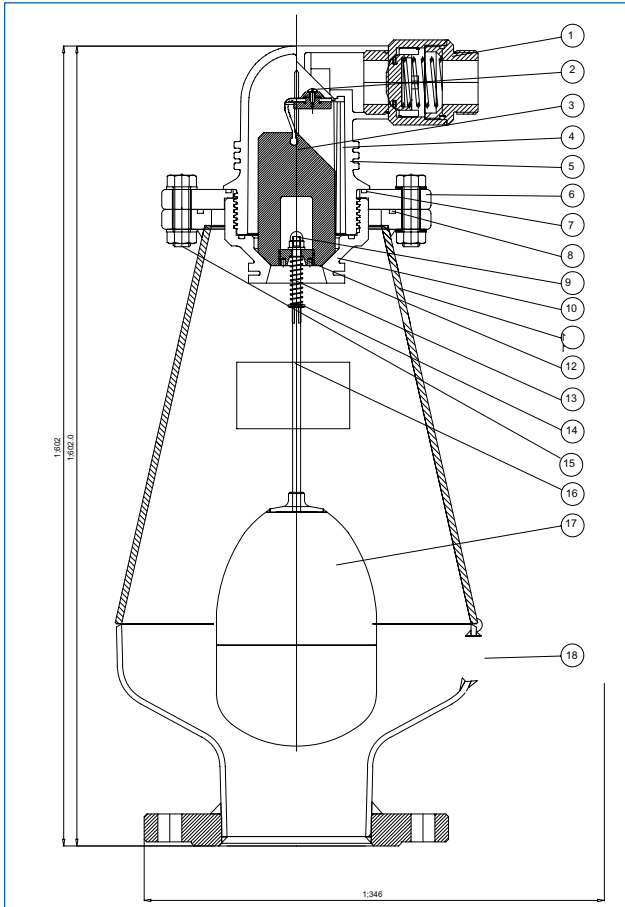

PARTS LIST AND SPECIFICATION

No.	Part	Material
1.	Drainage Elbow	Polypropylene
2.	Seal Plug Assembly	Reinforced Nylon
3.	Float	Foamed Polypropylene
4.	Clamping Stem	Reinforced Nylon
5.	Body	Reinforced Nylon
6.	Cover	Stainless Steel SAE 316
7.	O-Ring	BUNA-N / Viron
8.	O-Ring	BUNA-N / Viron
9.	Crown Nut	Stainless Steel SAE 316
10.	Plastic Base	Reinforced Nylon
11.	Stopper	Acetal
12.	Spring	Stainless Steel SAE 316
13.	Washer	Stainless Steel SAE 316
14.	Bolt and Nut	Galvanized Steel Chromate Plated
15.	Stem	Stainless Steel SAE 316
16.	Float	Stainless Steel SAE 316
17.	Ball Valve	Brass ASTM A124 / Polypropylene
18.	Body	Stainless Steel SAE 316

DIMENSIONS AND WEIGHTS

Nominal Size	A	B	Weight Lbs.
2" Threaded	16.6	25.3	36.3
2" Flanged	16.6	23.8	38.5
3"	16.6	23.8	40.7
4"	16.6	23.8	42.9
6"	16.6	24.0	46.2
8"	16.6	24.0	52.8

ORIFICE SIZE AREA inch²

Automatic Orifice	0.018
Kinetic Orifice	1.246

Threads: NPT.
Flanges are available in ANSI standards.

KINETIC AIR DISCHARGE CHART

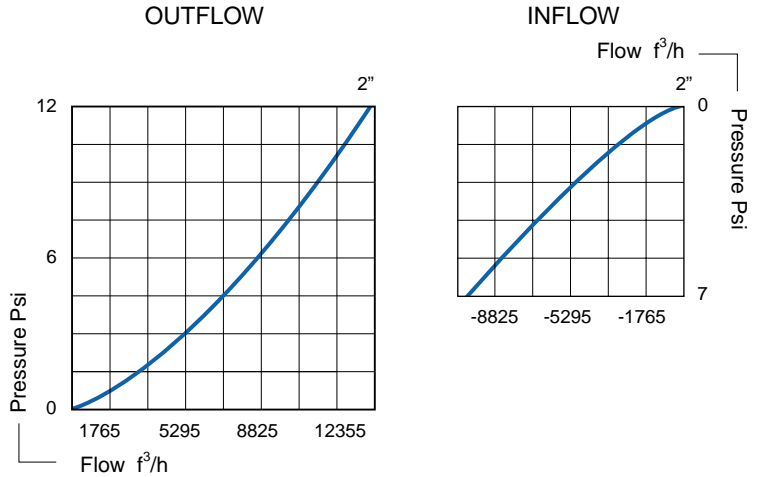

AUTOMATIC AIR DISCHARGE CHART

