

D-012, D-014, D-016 COMBINATION AIR VALVE FOR HIGH PRESSURE

Reliable operation reduces water hammer incidents.

Dynamic design allows high velocity air discharge, Preventing premature closing.

Lightweight, small dimensions, simple and reliable structure.

Special nozzle design: combination of bronze and E.P.D.M rubber, assures long-term maintenance free operation.

The drainage outlet enables removal of excess fluids.

Standard metal body - baked polyester coating.

Automatic component

A.R.I patent, Rolling Seal Mechanism:

- Dramatically reduces the possibility of obstruction by debris.
- Discharges high air flow rates up to 786 m³/h.
- One size orifice for a wide pressure range (up to 100 bar).
- Self cleaning mechanism.

All operating parts are made of specially selected corrosion resistant materials.

Working pressure range: 0.2-100 bar. (3-1400 psi).

Options:

D-012 Working pressure up to 25 bar. D-014 Working pressure up to 40 bar.
D-16 Working pressure up to 64 bar. D-100 Working pressure up to 100 bar.

Available in 2" (50mm) - 8" (200mm).



KINETIC AIR DISCHARGE CHART

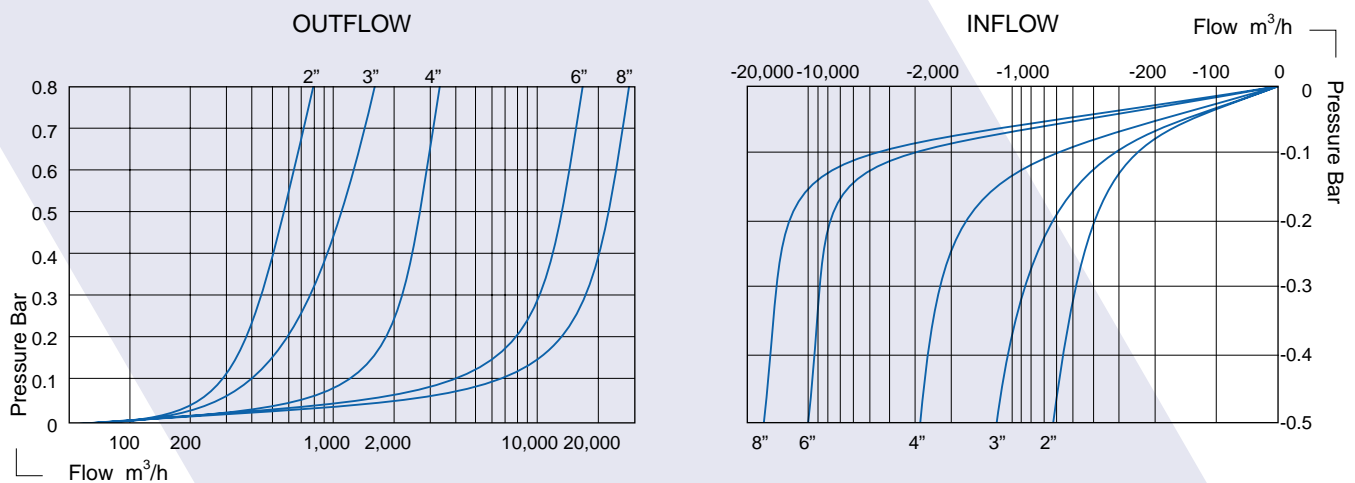

A.R.I. Flow Control Accessories

Kfar Charuv, 12932 Israel Tel. 972-6-6761988 Fax. 972-6-6763402

<http://arivalves.com>

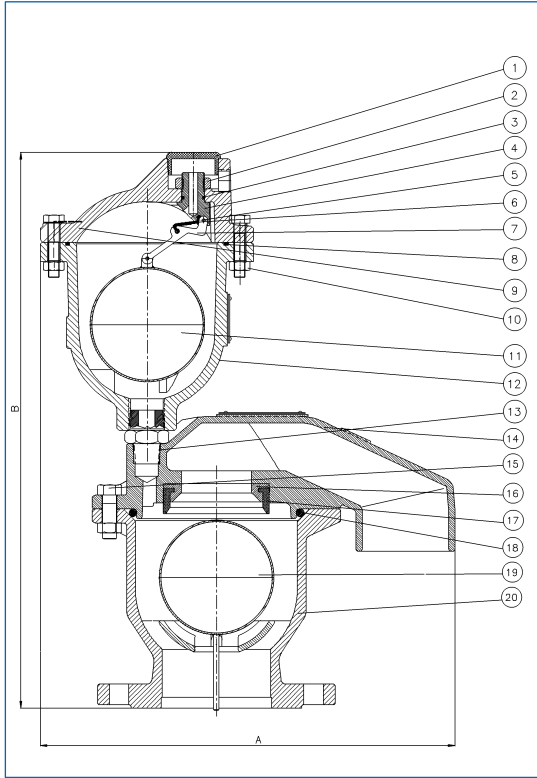

PARTS LIST AND SPECIFICATION

No.	Part	Material
1.	Plastic Cover	Polypropylene
2.	Nut	Brass ASTM B-124
3.	O-Ring	Buna-N
4.	Nozzle	Acetal
5.	Pin	Stainless Steel SAE 303
6.	Rolling Seal	Rubber E.P.D.M.
7.	Lever Seal	Acetal
8.	O-Ring	Buan-N
9.	Cover	PN 25, PN 40 Sphero nodular ASTM A-536-60-40-18 PN 40-100 Cast Steel ASTM A-216 WCB
10.	Bolt and Nut	Galvanized Steel Chromate Plated
11.	Float	Stainless Steel SAE 304L
12.	Body	PN 25, PN 40 Sphero nodular ASTM A-536-60-40-18 PN 40-100 Cast Steel ASTM A-216 WCB
13.	Adapter	Brass ASTM B124
14.	Cover	Steel DIN-ST37
15.	Bolt and Nut	Galvanized Steel Chromate Plated
16.	Nozzle Seat	Bronze ASTM B62 B271 C83600
17.	Nozzle Seal	Natural and Synthetic Rubber
18.	O-Ring	Buna-N
19.	Float	2" - 4" Polycarbonate 6" - 8" Stainless Steel 304L
20.	Body	PN 25, PN 40 Sphero nodular ASTM A-536-60-40-18 PN 40-100 Cast Steel ASTM A-216 WCB
■	Basket	2" Polypropylene
■	Protective Cover	6",8" Alum. AL-356

DIMENSIONS AND WEIGHTS

Nominal Size	Dimensions mm		Weight Kg (for PN25)	Weight Kg (for PN40)	Orifice Size Area: Kin. Valve mm ² (PN25)	Outlet
	A	B				
50 mm 2"	330	454	30	32	794	1.5" female threaded
80 mm 3"	331	504	30	46	1809	
100 mm 4"	384	514	39	61	3317	
150 mm 6"	576	729	89	105	17662	
200 mm 8"	576	729	97	110	17662	

* Automatic Valve Orifice Area: 15 mm² for all valves

Flanges are available in BS/ISO/ANSI standards.

AUTOMATIC AIR DISCHARGE CHART

